

# **Shunt Reactor Switching**

## **Dielectric stresses produced by circuit-breakers to shunt reactors.**

**Presentation made during the IEEE Transformers Committee meeting,  
Amsterdam, Netherlands, April 2001**

**Presented by:**

Pierre Riffon P. Eng.  
Hydro-Québec  
Test Specialist  
Quality Control Department  
01/04/11

## **Circuit-breaker testing**

### **1- Circuit- breaker tests for shunt reactor switching are covered by the following guides :**

**A- Technical Report IEC 1233, 1994 "High-voltage alternating current circuit-breaker - Inductive load switching".**

**B- IEEE Std. C37.015-1993 "IEEE Application Guide for Shunt Reactor Switching".**

These two documents are technically identical since they are the result of a cooperative effort between a WG of the IEEE High Voltage Circuit-breaker Subcommittee and a Task Force of the IEC Technical Committee SC17A.

## **Circuit-breaker testing**

### **2- Purpose of the circuit-breaker tests**

- a) To determine the interrupting window without re-ignition.
- b) To determine the current chopping characteristics of the circuit-breaker.
- c) To determine the worst probable overvoltage that could appear across the reactor and across the circuit-breaker.

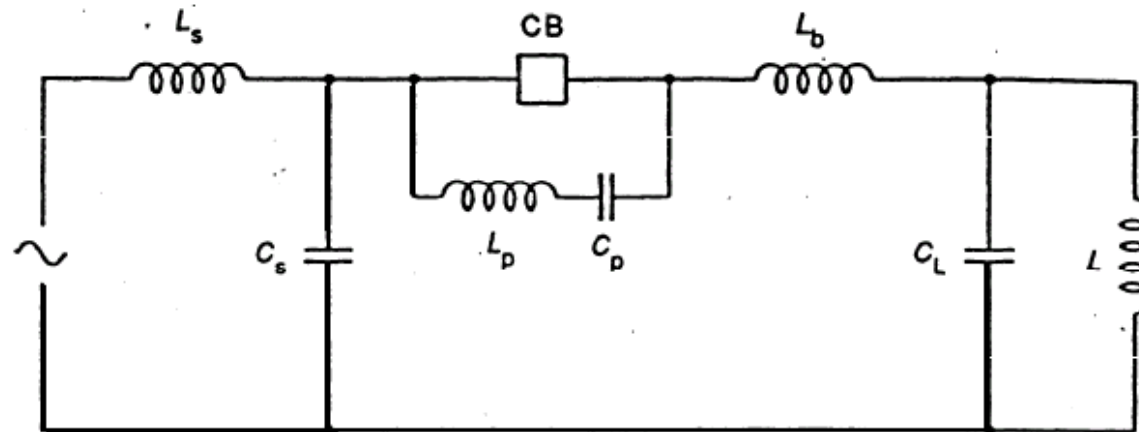

IEC 566/94

- $L_s$  = supply **side** (short-circuit) inductance
- $C_s$  = supply **side** capacitance
- $L_p, C_p$  = **stray** inductance and capacitance **across** circuit-breaker CB
- $L_b$  = inductance of **re-ignition** circuit
- $C_L$  = capacitance **parallel** to the reactor
- $L$  = inductance of reactor

Figure 7 – Single-phase. equivalent circuit

**Table 3 – Test duties at reactor current switching tests**

Test duty	Number of breaking operations		Test current determined by
	Three-phase	Single-phase	
1	20	20	Load circuit 1 (4.6.1)
2	20	20	Load circuit 2 (4.6.2)
3		18	Load circuit 2 (4.6.2)

**4.6.1 Load circuit 1**

The reactance  $L$  of the load circuit shall be adjusted to give the following breaking currents:

Rated voltage kV	Test current A	
12 to 36	1 600	} ±20 %
52 to 72,5	630	
≥ 100	315	

**4.6.2 Load circuit 2**

The reactance  $L$  of the load shall be adjusted to give the following breaking currents:

Rated voltage kV	Test current A	
12 to 36	500	} ±20 %
52 to 72,5	200	
≥ 100	100	

## **Circuit-breaker testing**

### **Tests results:**

- 1- Re-ignition performance vs arcing time ;**
- 2- Chopping number (overvoltage) vs arcing time ;**
- 3- Re-ignition voltage vs arcing time.**

Graph no.1; I = 250 A; Minimum gas pressure

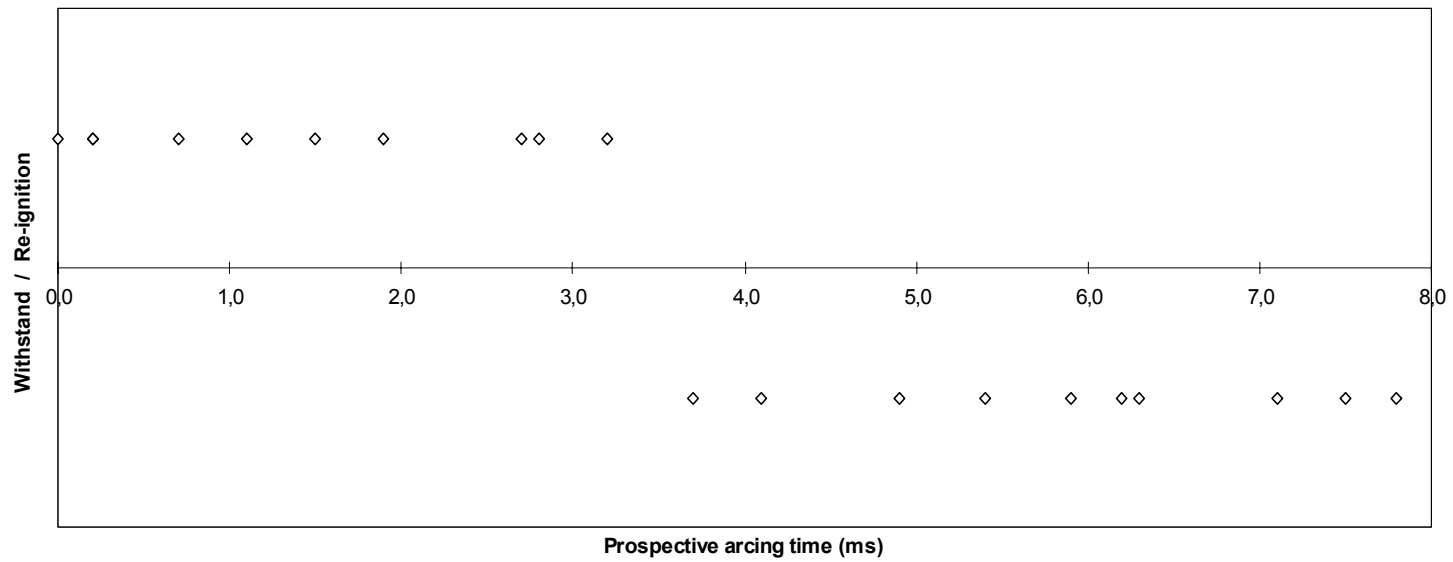

Graph no.2: I = 250 A; Minimum gas pressure

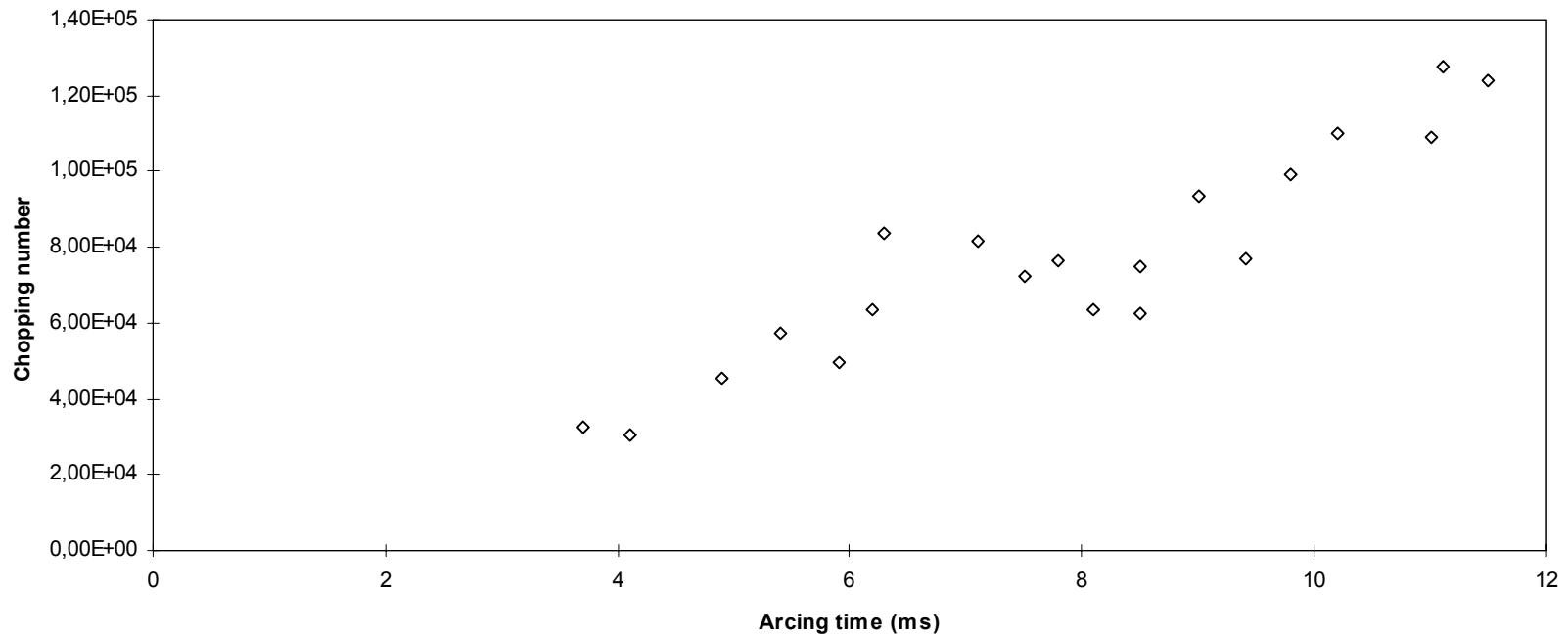

Graph no. 3: I = 250 A; Minimum gas pressure

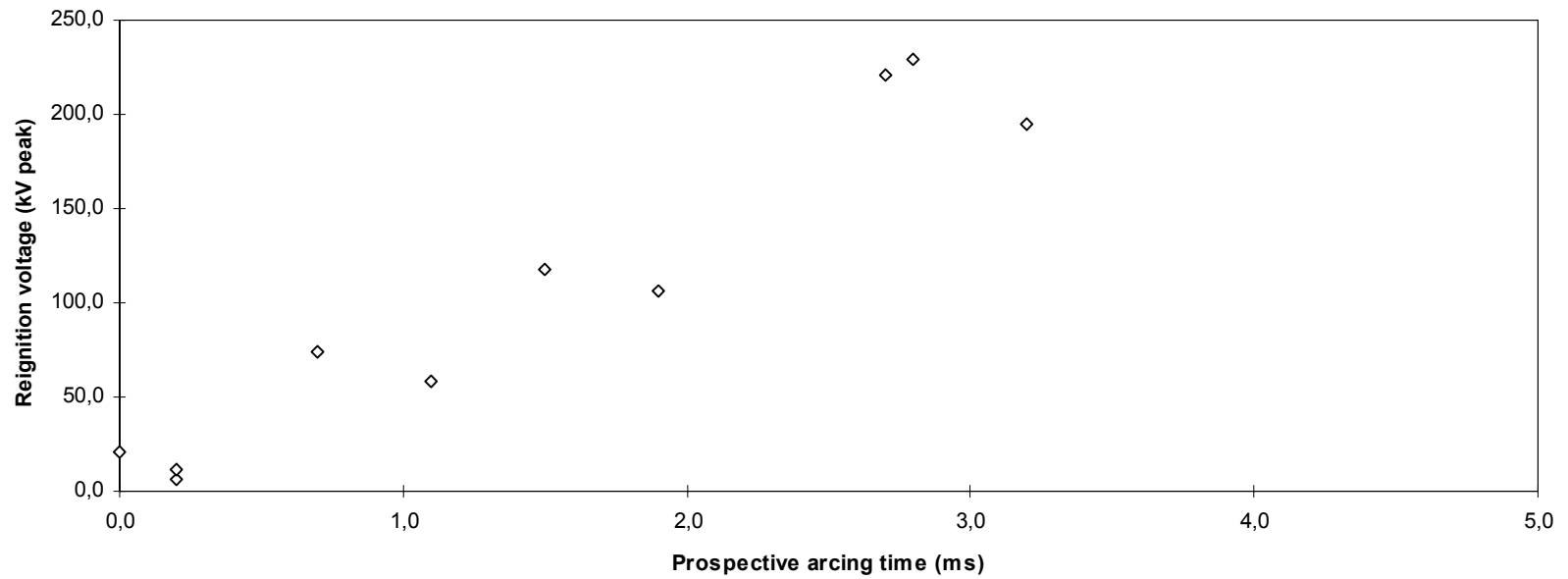

**Dielectric stresses imposed  
on shunt reactors :**

**Important aspect :**

Shunt reactor switching is a daily event (in some cases, shunt reactors may be switched on and off several times during the same day)

## **Dielectric stresses imposed on shunt reactors :**

### **1- Ideal case, no re-ignition and no current chopping**

- Type of stresses: Switching surge type of waveshape (damped oscillatory overvoltage). Could be close to lightning impulse waveshape for dry-type reactors.

## **Dielectric stresses imposed on shunt reactors :**

### **1- Ideal case, no re-ignition and no current chopping**

- Frequency :

$$f_{transient} = \frac{1}{2\pi\sqrt{LC_L}}$$

Typical frequencies :

-  $\approx 1,0$  to 41 kHz for oil-immersed reactor (stray capacitance  $\approx 0,8$  to 4 nF);

-  $>100$  kHz for dry-type shunt reactors (stray capacitance  $\approx 100$  to 500 pF)

REACTOR CURRENT

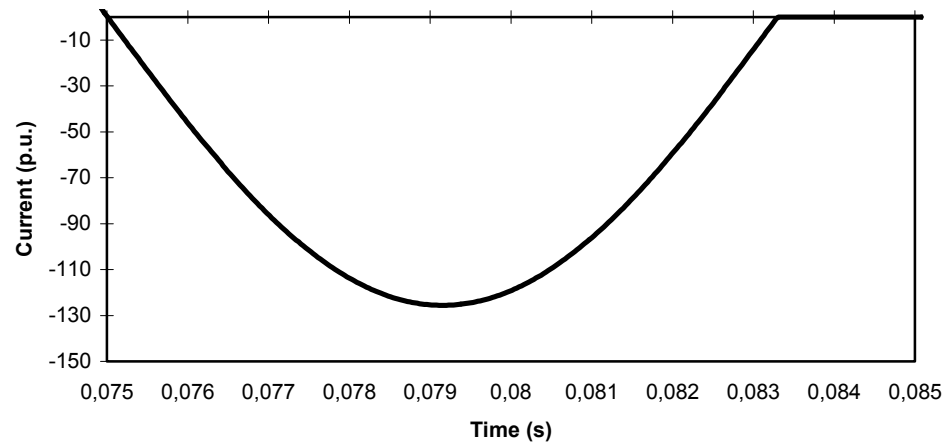

REACTOR VOLTAGE

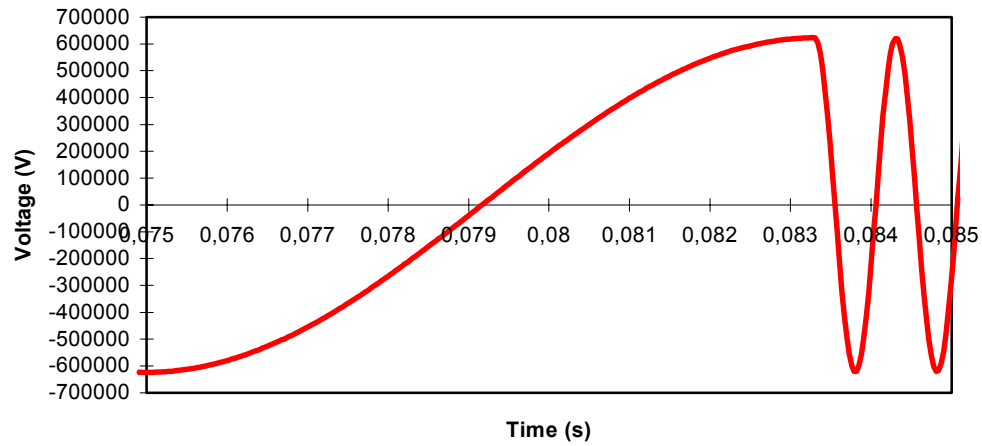

IDEAL CASE

## **Dielectric stresses imposed on shunt reactors :**

### **1- Ideal case, no re-ignition and no current chopping**

- Reactor transient voltage amplitude (grounded neutral):

$$U_{peak} = \sqrt{2} \times U_n / \sqrt{3}$$

**This transient voltage is not severe since it is the phase to ground peak voltage.**

## **Dielectric stresses imposed on shunt reactors :**

1- Ideal case, no re-ignition and no current chopping  
(continued)

**Ideal circuit-breakers do not exist, some are more sensitive to re-ignitions while others may chopped considerably the current.**

## **Dielectric stresses imposed on shunt reactors :**

2- Real case, no re-ignition and current chopping

**Current chopping is circuit-breaker dependent.**

For example :

- For air-blast circuit-breakers : Typical chopping number :  
 $15 - 25 \times 10^4$ ;
- For SF<sub>6</sub> circuit-breakers : Typical chopping number : 4 -  
 $17 \times 10^4$ ;
- For minimum oil circuit-breakers : Typical chopping  
number :  $7 - 10 \times 10^4$ ;

## **Dielectric stresses imposed on shunt reactors:**

**2- Real case, no re-ignition and current chopping (continued)**

$$\text{Chopping number } (\lambda) = i_{ch} / \sqrt{C_t}$$

Where:

$i_{ch}$  = Chopping current;

$C_t$  = Total capacitance seen by the circuit-breaker (stray capacitance on the shunt reactor + parallel capacitance across the circuit-breaker pole).

**Chopping results in an overvoltage across the shunt reactor and across the circuit-breaker.**

Figure 2 illustrates current chopping phenomena and figure 3 defines the different overvoltages occurring at chopping and reignition.

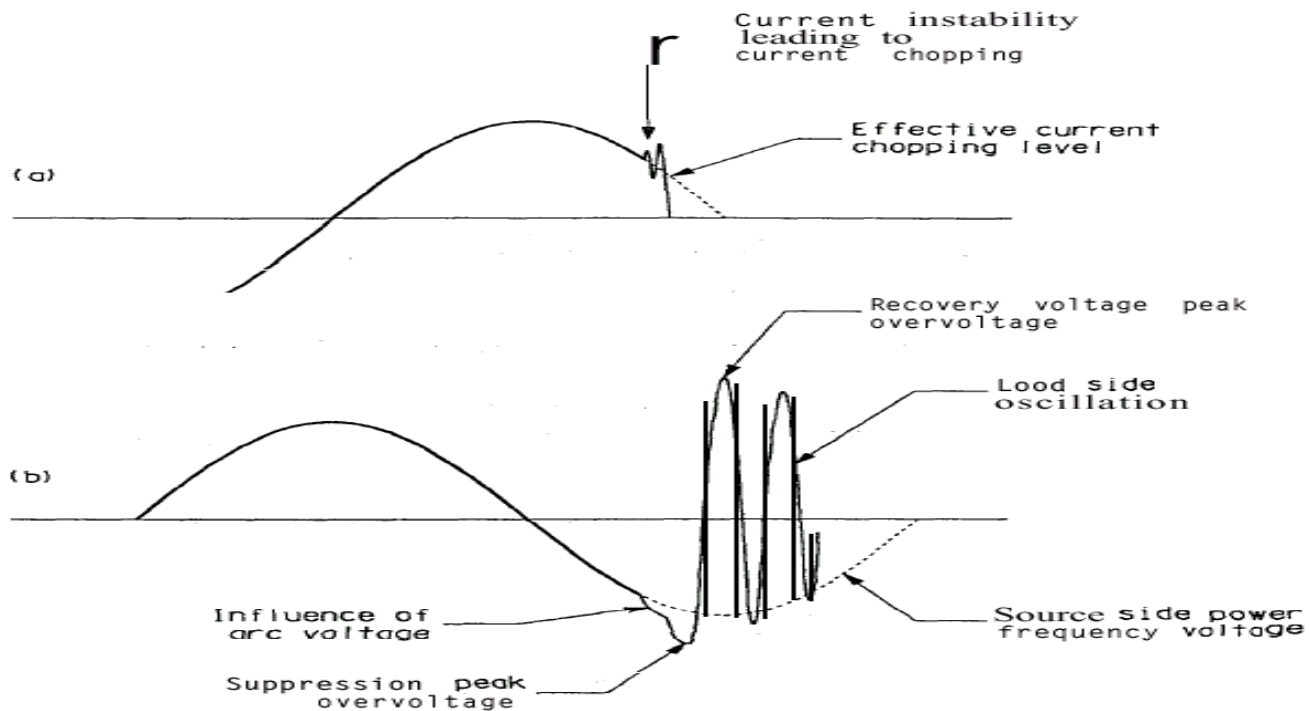

a) Current through circuit breaker

b) Voltage across shunt reactor

Figure 2-Current chopping phenomena

## **Dielectric stresses imposed on shunt reactors:**

### **2- Real case, no re-ignition and current chopping (continued)**

The trapped energy in the reactor at the instant of current chopping ( $\frac{1}{2} \times L (i_{ch})^2$ ) has to be transferred to the parallel capacitance. Thus,

$$\frac{1}{2} \times L \times (i_{ch})^2 = \frac{1}{2} \times C_T \times (\Delta V)^2$$

Where " **$\Delta V$** " is the overvoltage produced by current chopping.

## **Dielectric stresses imposed on shunt reactors :**

### **2- Real case, no re-ignition and current chopping (continued)**

For a given shunt reactor "L", the overvoltage produced is proportional to the current chopped. Moreover, a reactor with a large stray capacitance (e.g. oil-immersed) will be less affected by the current chopping (larger  $C_T$ ). And,

$$\Delta V = i_{ch} \times \sqrt{L/C_T}$$

## **Dielectric stresses imposed on shunt reactors :**

### **2- Real case, no re-ignition and current chopping (continued)**

The amplitude of **the current chopping is proportional to the arcing time** of the circuit breaker. For a longer arcing time, the "interrupting strength" of the circuit-breaker is larger and the breaker can chop more current.

## **Dielectric stresses imposed on shunt reactors :**

### 2- Real case, no re-ignition and current chopping (continued)

- Type of stresses: **Switching surge** type of waveshape (damped oscillatory overvoltage). Could be close to lightning impulse waveshape for dry-type reactors.
- Frequency :

$$f_{transient} = \frac{1}{2\pi\sqrt{LC_L}}$$

## **Dielectric stresses imposed on shunt reactors :**

### **2- Real case, no re-ignition and current chopping (continued)**

Typical frequencies:

- $\approx 1,0$  to 41 kHz for oil-immersed reactors (stray capacitance  $\approx 0,8$  to 4 nF);
- $>100$  kHz for dry-type shunt reactors (stray capacitance  $\approx 100$  to 500 pF) ;

## **Dielectric stresses imposed on shunt reactors :**

2- Real case, no re-ignition and current chopping (continued)

- Reactor transient amplitude (grounded neutral):

$$U_{peak} = k_a \times \sqrt{2} \times U_n / \sqrt{3}$$

Where:

$k_a$ : Overshoot factor due to current chopping

## **Dielectric stresses imposed on shunt reactors :**

### **2- Real case, no re-ignition and current chopping (continued)**

This **transient voltage can be severe** depending of the circuit-breaker chopping characteristics and on the shunt reactor value and its stray capacitance.

The Hydro-Québec's technical approach on this problem consists, for each specific case, to evaluate the **worst probable** overvoltage that will be imposed **on a specific combination "reactor-circuit-breaker"**.

## **Dielectric stresses imposed on shunt reactors :**

### **2- Real case, no re-ignition and current chopping (continued)**

The test results (chopping number vs arcing time) are evaluated and an equation of the chopping number vs arcing time is derived from the test results (linear regression of the results obtained). Since this has also a statistical behavior (that it is why a large number of tests are required), **the worst probable overvoltage is calculated considering the longest possible arcing time ( $t_{\text{arc max.}}$ ) without re-ignition (i.e. 8,3 ms for 60 Hz application) and by using "3 x  $S_e$ " (99,9% of the cases) where " $S_e$ " is the "standard error of estimate".**

## **Dielectric stresses imposed on shunt reactors:**

### **2- Real case, no re-ignition and current chopping (continued)**

The equations used are:

$$\lambda_{\max} = \lambda_0 + B \times t_{\text{arc max.}} + 3 \times S_e$$

and

$$k_a = \sqrt{1 + \frac{3 \times N \times \lambda_{\max}^2}{2 \times \omega \times Q}}$$

W h e r e :

N : Number of interrupting units in series;

$\lambda_{\max}$ : Worst probable chopping number derived from test result analysis;

$\omega$ :  $2 \times \pi \times f$ ;

Q : Three-phase reactive power of the shunt reactor;

B and  $\lambda_0$ : Equation constants.

## **Dielectric stresses imposed on shunt reactors :**

**2- Real case, no re-ignition and current chopping (continued)**

and

$$U_{peak} = k_a \times \sqrt{2} \times \frac{U_n}{\sqrt{3}}$$

**Note:** IEC technical report and IEEE guide suggest to use "2 x  $S_e$ " (97,7 % of the cases). Within Hydro-Québec, shunt reactors are normally used on 800 kV systems (directly connected) and the margin between the protective level of the surge arrester and the SIWL of the reactor is much lower than for lower system voltages. Because **800 kV** shunt reactors are **strategic equipment** and because of their replacement cost, a "**3 x  $S_e$** " **criteria** is used.

## **Dielectric stresses imposed on shunt reactors :**

### **2- Real case, no re-ignition and current chopping (continued)**

As a typical example, a **800 kV SF<sub>6</sub> puffer type circuit-breaker** used to switch a **330 MVA<sub>r</sub> reactor** (3 single phase units rated 110 MVA<sub>r</sub>) may produced overvoltages **"k<sub>a</sub>" in the range of 1,32 p.u.**

The same circuit-breaker used to switch a **165 MVA<sub>r</sub> reactor** (3 single phase units rated 55 MVA<sub>r</sub>) may produced overvoltages **"k<sub>a</sub>" in the range of 1,55 p.u.**

## **Dielectric stresses imposed on shunt reactors :**

2- Real case, no re-ignition and current chopping (continued)

**For extra-high voltage applications (550 kV and 800 kV) ,** because of **the low margin between the SIPL and SIWL** (typically 25%) and because that reactor switching is a **daily event**, we do recommend that the calculated overvoltage peak to be less than **0,68 x SIWL (0,8 (ageing) x 0,85 (margin) = 0,68)**. For these cases, **the arrester can not give a proper protection**, mainly if we consider a certain dielectric strength reduction of the reactor due to ageing.

## **Dielectric stresses imposed on shunt reactors :**

**2- Real case, no re-ignition and current chopping (continued)**

**For high-voltage (< 362 kV) and for medium voltage applications, the SIPL of the shunt reactor surge arrester is relatively low and the margin between the SIPL and the SIWL is larger than 32%. For these cases, the parallel surge arrester is normally giving a proper shunt reactor switching overvoltage protection even for aged shunt reactors.**

## **Dielectric stresses imposed on shunt reactors :**

### **3- Real case, re-ignition and current chopping**

**Re-ignition** of a circuit-breaker **occurs when the TRV applied to the circuit-breaker is higher than the "dynamic" voltage withstand capability of the circuit-breaker during an opening operation.**

Re-ignition occurs normally with **small arcing times**. For high voltage **SF<sub>6</sub> circuit-breakers**, it is typical that **arcing times lower than 4 ms lead to re-ignitions.**

## **Dielectric stresses imposed on shunt reactors :**

### **3- Real case, re-ignition and current chopping (continued)**

Type of stresses: **Fast transient type** of waveshape (damped oscillatory overvoltage, lightning impulse or chopped wave).

- *Frequency :*

$$f_{transient} = \frac{1}{2\pi} \times \sqrt{\frac{C_L + C_s}{L_B \times C_L \times C_s}}$$

Where:

$L_B$ : Inductance of the re-ignition circuit (between the source side capacitor and the shunt reactor).

$C_s$ : Source side capacitance;

$C_L$ : Load side capacitance.

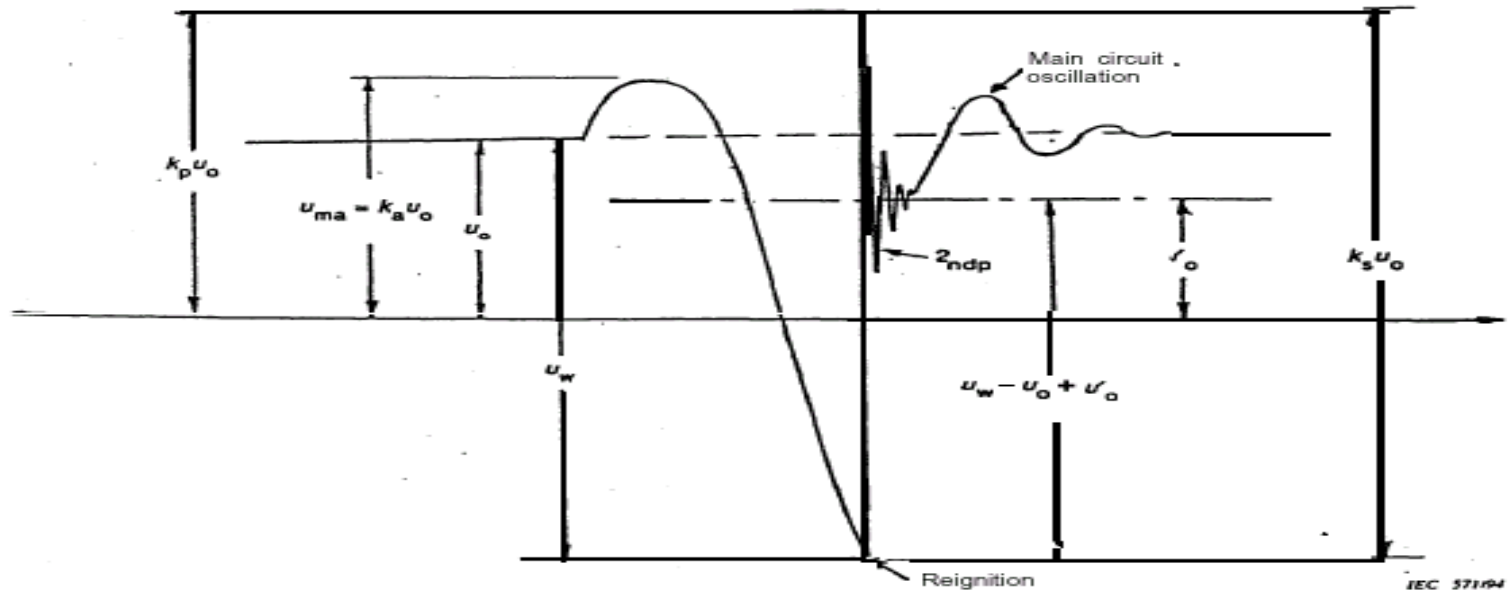

- $2_{ndp}$  = second **parallel** oscillation
- $u_c$  = power frequency **crest** voltage phase-to-earth
- $u_o'$  = supply **side** capacitance voltage **after** charge redistribution at re-ignition
- $u_{ma} = k_a u_c$  = suppression peak voltage
- $u_w$  = voltage **across** circuit-breaker **at** re-ignition
- $k_p u_o$  = re-ignition overvoltage to **earth**
- $k_s u_o$  = peak-to-peak voltage excursion at re-ignition

**Figure 72 – Re-ignition near the recovery peak for a circuit with low supply side capacitance**

## **Dielectric stresses imposed on shunt reactors :**

### **3- Real case, re-ignition and current chopping (continued)**

Typical frequencies:

- From 50 kHz to 1,0 MHz. This frequency **is mainly dependent of the stray capacitance of the shunt reactor** ( $C_S \gg C_L$ ) and the length of re-ignition circuit ( $L_B$ ) between the source side capacitance and the shunt reactor.

## **Dielectric stresses imposed on shunt reactors:**

### 3- Real case, re-ignition and current chopping (continued)

- Reactor transient voltage amplitude (grounded neutral) :

a) Before the re-ignition, worst case :

$$U_{peak-to-ground} = k_a \times \sqrt{2} \times \frac{U_n}{\sqrt{3}} \text{ (same as for current chopping case)}$$

## **Dielectric stresses imposed on shunt reactors :**

### 3- Real case, re-ignition and current chopping (continued)

b) After re-ignition, worst case (re-ignition at the peak of the recovery voltage):

$$U_{\text{peak-to-ground}} = \left[ (1 + \beta) \times (1 + k_a) \times \left( \frac{C_s}{C_s - C_L} \right) - k_a \right] \times \sqrt{2} \times \frac{U_n}{\sqrt{3}}$$

Where :

$\beta$  : Damping factor of the re-ignition transient, normally  $\beta \leq 0,5$  ;  
 $k_a$  : Suppression peak overvoltage caused by current chopping ;  
 $C_s$  : Source side capacitance ;  
 $C_L$  : Load side capacitance .

And generally,  $C_s \gg \gg C_L$

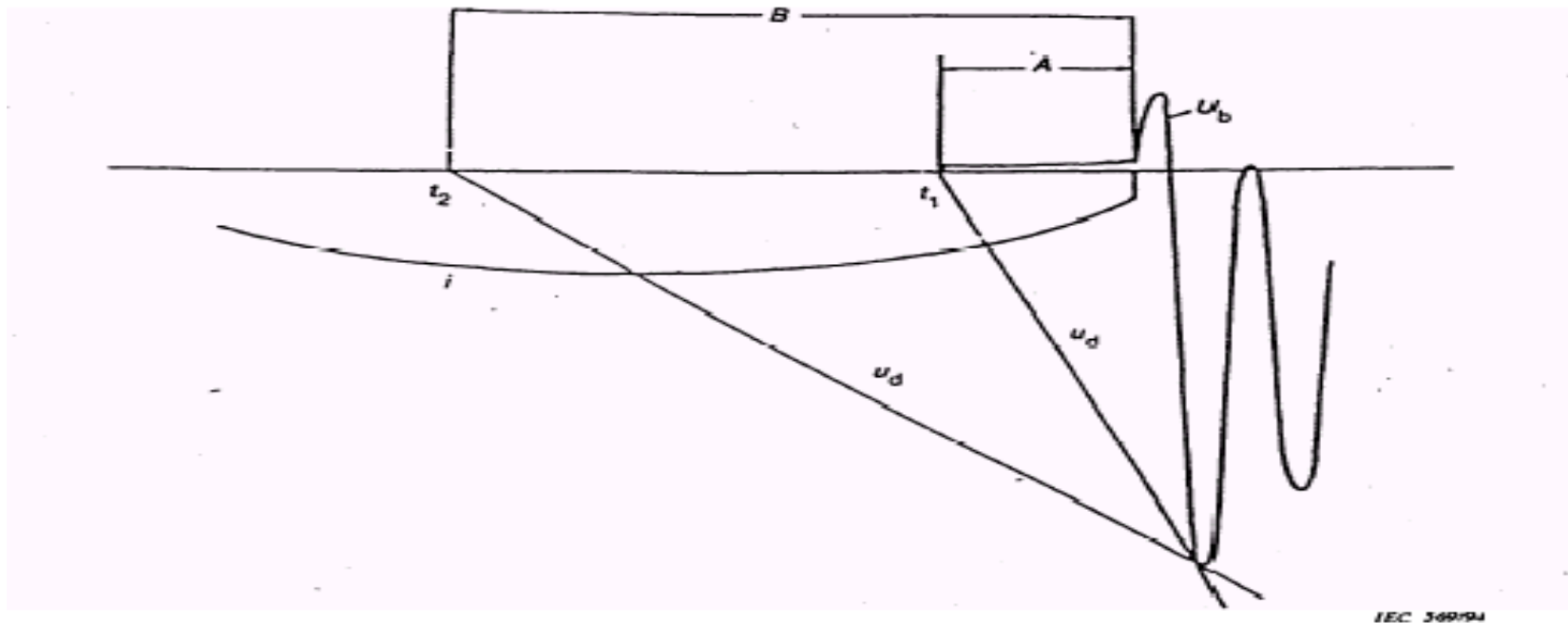

- $i$  = current through circuit-breaker
- $u_b$  = voltage across circuit-breaker
- $u_d$  = dielectric recovery of circuit-breaker
- $t_1$  = latest contact separation time leading to re-ignition for circuit-breaker with fast dielectric recovery
- $t_2$  = latest contact separation leading to re-ignition for circuit-breaker with slow dielectric recovery
- A = re-ignition window for circuit-breaker with fast recovery
- B = re-ignition window for circuit-breaker with slow recovery

Figure 10 – Re-ignition window

## **Dielectric stresses imposed on shunt reactors :**

### **3- Real case, re-ignition and current chopping (continued)**

As for the case of current chopping, **for high voltage and medium voltage shunt reactors** ( $\leq 345$  kV), the surge arrester **will protect adequately the reactor** against the maximum phase-to-ground peak voltage. Nevertheless, **for extra high voltage shunt reactors** (500 and 765 kV), **the arrester may not adequately protect the reactor** if we consider this type of stress as **a daily event** (margin of 20% for ageing and 15 % on the LIWL, 0,68 p.u. of the LIWL).

## **Dielectric stresses imposed on shunt reactors :**

### **3- Real case, re-ignition and current chopping (continued)**

The phase-to-ground overvoltage produced by a re-ignition is not the worst dielectric stress generated during this event. **The  $dv/dt$  applied to the shunt reactor during a re-ignition can be extremely severe and the surge arrester connected across the shunt reactor will not protect it.**

## Dielectric stresses on shunt reactors during re-ignitions

Nominal system voltage (kV)	BIL (kV)	Chopped wave (kV)	LIPL (2,5 x phase-to-ground voltage peak) (kV)	2 x LIPL (ultimate maximum dv/dt during re-ignition) (kV)	dv/dt stresses (% of the chopped wave level) (%)	Phase-to-ground overvoltage (% of the LIW L)*
15	110	120	30,6	61,2	51,0	23,9
25	150	165	51,0	102,1	61,9	29,3
34,5	200	220	70,4	140,8	64,0	30,3
45	250	275	91,9	183,7	66,8	31,6
69	250	275	140,8	281,7	102,4	48,5
69	350	385	140,8	281,7	73,2	34,6
115	350	385	234,7	469,5	121,9	57,7
115	450	495	234,7	469,5	94,8	44,9
115	550	605	234,7	469,5	77,6	36,7
138	450	495	281,7	563,4	113,8	53,8
138	550	605	281,7	563,4	93,1	44,0
138	650	715	281,7	563,4	78,8	37,3
161	550	605	328,6	657,3	108,6	51,4
161	650	715	328,6	657,3	91,9	43,5
161	750	825	328,6	657,3	79,7	37,7
230	650	715	469,5	939,0	131,3	62,1
230	750	825	469,5	939,0	113,8	53,8
230	825	905	469,5	939,0	103,8	48,9
230	900	990	469,5	939,0	94,8	44,9
345	900	990	704,2	1408,5	142,3	67,3
345	1050	1155	704,2	1408,5	121,9	57,7
345	1175	1290	704,2	1408,5	109,2	51,5
500	1300	1430	1020,6	2041,2	142,7	67,5
500	1425	1570	1020,6	2041,2	130,0	61,6
500	1550	1705	1020,6	2041,2	119,7	56,6
500	1675	1845	1020,6	2041,2	110,6	52,4
765	1800	1980	1561,5	3123,1	157,7	74,6
765	1925	2120	1561,5	3123,1	147,3	69,8
765	2050	2255	1561,5	3123,1	138,5	65,5

Cases where the re-ignition dv/dt is higher than the chopped wave level  
 Cases where the re-ignition dv/dt is higher than 68% of the chopped wave level (required margin)  
 \*: Considering a damping factor of 0,5 and a  $k_a$  of 1,3

## **Dielectric stresses imposed on shunt reactors :**

### **3- Real case, re-ignition and current chopping (continued)**

For **reactors rated 69 kV to 161 kV**, the  $dv/dt$  produced by a re-ignition **is in excess of the required margin for aged reactors** (more than 68 % of the CWWL). For these cases, **re-ignitions can be accepted as an accidental event.**

**It should be noted that for some cases** (lower BIL ratings of each nominal voltage class), **the  $dv/dt$  produced by a re-ignition will exceed the  $dv/dt$  produced by a chopped wave.** **For these cases, re-ignitions of circuit-breaker shall be avoided.**

## **Dielectric stresses imposed on shunt reactors :**

### **3- Real case, re-ignition and current chopping (continued)**

As shown in the table, **for medium voltage shunt reactors** ( $\leq 45$  kV), the  $dv/dt$  produced during single or multiple re-ignitions event (the later only applicable to vacuum circuit-breakers, max. value =  $2 \times LIPL$ ) **is generally well protected** by the surge arrester (less than 68% of the CWWL) because of the huge margin between the protective level of the surge arrester and the chopped wave rated level of the shunt reactor.

## **Dielectric stresses imposed on shunt reactors :**

3- Real case, re-ignition and current chopping (continued)

**For reactors rated above 161 kV, the  $dv/dt$  produced by a re-ignition is always higher than the chopped wave rating of the reactor. For these cases, the  $dv/dt$  produced by a re-ignition will exceed the  $dv/dt$  produced by a chopped wave and re-ignitions of the circuit-breaker shall be avoided.**

## **Dielectric stresses imposed on shunt reactors :**

### **4- Ways to limit overvoltages**

**a) Shunt reactor arrester protection (shall always be used, normal practice ) :**

#### **Advantage:**

- **Does limit the phase-to-ground overvoltage** applied to the reactor;

## **Dielectric stresses imposed on shunt reactors :**

### 4- Ways to limit overvoltages (continued)

#### a) Shunt reactor arrester protection (shall always be used, normal practice ) :

##### Disadvantages:

- **Does not give appropriate protection against the  $dv/dt$**  produced during a re-ignition (mainly for reactors rated 69 kV and above).
- **Not effective to reduce the probability of a re-ignition** of the circuit-breaker.

## **Dielectric stresses imposed on shunt reactors :**

### **4- Ways to limit overvoltages (continued)**

**b) Opening resistors (used in the past on air-blast circuit-breakers, normally not offered today):**

**Advantages:**

- **Does limit the amplitude of the current chopping;**
- **Effective to limit the chopping overvoltage;**
- **Effective to limit the probability of re-ignition and effective to limit the overvoltage caused by a re-ignition.**

## **Dielectric stresses imposed on shunt reactors :**

### **4- Ways to limit overvoltages (continued)**

**b) Opening resistors (used in the past on air-blast circuit-breakers, normally not offered today; continued) :**

**Disadvantages :**

- **Expensive** ;
- **Reduced reliability** of the circuit-breaker ;
- Increase the **need of circuit-breaker maintenance** ;
- **Thermal limitation**.

## Dielectric stresses imposed on shunt reactors :

### 4- Ways to limit overvoltages (continued)

c) Arresters in parallel with the circuit-breaker (solution used on some SF<sub>6</sub> circuit-breakers) :

#### Advantages :

- Does limit the amplitude of the TRV across the circuit-breaker, **effective to limit the re-ignition window**;
- Effective to **limit the resulting dv/dt in case of a re-ignition**;
- **Passive element.**

## Dielectric stresses imposed on shunt reactors :

### 4- Ways to limit overvoltages (continued)

c) Arresters in parallel with the circuit-breaker (solution used on some SF<sub>6</sub> circuit-breakers; continued) :

Disadvantages :

- Expensive;
- Thermal limitation.

## Dielectric stresses imposed on shunt reactors :

### 4- Ways to limit overvoltages (continued)

#### d) Synchronous switching (today's preferred solution) :

##### Advantages :

- Does forbid opening operations within the re-ignition window;
- Cost (not necessarily for MV circuit-breakers);
- Easy to implement for all types of circuit-breakers.

## **Dielectric stresses imposed on shunt reactors :**

### **4- Ways to limit overvoltages (continued)**

**d) Synchronous switching (today's preferred solution;  
continued) :**

**Disadvantages :**

- **Need to carry extensive circuit-breaker testing** for the evaluation of the re-ignition window and current chopping characteristics;

## **Dielectric stresses imposed on shunt reactors :**

### 4- Ways to limit overvoltages (continued)

d) Synchronous switching (today's preferred solution;  
continued) :

#### Disadvantages :

- **Need to carry special mechanical tests** for the determination of the scatter in opening times in relation with control voltage, gas pressure, available energy in the operating mechanism, ambient temperature, etc...;
- **Electronic component** (sensitivity to EMC).

## **Conclusions**

- Switching of shunt reactors may produce severe dielectric stresses to shunt reactors;
- Determination of circuit-breaker characteristics (test procedure) in relation with shunt reactor switching (current chopping and re-ignition window) is well defined in IEC and IEEE;
- C57.21 (IEEE Standards Requirements Terminology, and Test Code for shunt reactors Rated Over 500 kVA) shall refer to these documents for the evaluation of the overvoltages;

**We do propose to use "3 x Se" instead of "2 X Se" for extra high voltage shunt reactors (500 and 765 kV) because of the reduced protective margin.**

---

## Conclusions

- C57.21 shall prescribe maximum overvoltage levels that shunt reactors are able to withstand as a daily event (considering ageing and safety margin). This conclusion can be also applicable to power transformers.

*a) We propose that the maximum overvoltage produced by current chopping shall not exceed 68% of the rated SIWL rating of the reactor or 56% of the rated BIL rating (68% x 83% x LIWL) if SIWL is not defined;*

*b) We propose that the maximum dv/dt produced during re-ignition (if re-ignitions are allowed as a possible daily event) to be less than 68% of the rated CWWL of the reactor;*

## Conclusions

- c) We propose to add in C57.21 that shunt reactors rated 230 kV and above are not designed to withstand the stresses produced by a re-ignition of the circuit-breaker unless special measures have been taken in the reactor design or in the circuit-breaker design.
- d) We propose to add in C57.21 that in no case, the  $dv/dt$  produced during a re-ignition should exceed the rated CWWL of the shunt reactor.